

**MANUAL NUMBER HG-1**

# **TRAC REGULATOR CO., INC.**

## **MAINTENANCE MANUAL FOR GAS PRESSURE REDUCING VALVE TRAC STYLE 'HG'**



**TRAC Regulator Company Inc.  
160 South Terrace Avenue  
Mount Vernon, New York USA 10550-2408**

**Phone: (914) 699-9352  
Fax: (914) 699-9367**

**FOR GENERAL DISTRIBUTION**



## TABLE OF CONTENTS

Section		Page
1	GENERAL INFORMATION AND SAFETY PRECAUTIONS	
	Introduction.....	1
	Principles of Operation.....	1
2	OPERATING INSTRUCTIONS	
	Pressure Adjustment.....	2
	Changing Pressure Setting .....	2
	In Service Operation .....	2
3	INSTALLATION	
	Installation .....	3
	Bypass Installation .....	3
4	MAINTENANCE	
	Disassembly of 1/4" to 1-1/2" Pressure Reducing Valve .....	4
	Disassembly of 2" Pressure Reducing Valve.....	6
	Inspection & Replacement of Parts.....	8
	Reassembly.....	8
	Reference Data .....	8
5	TROUBLESHOOTING	
	Troubleshooting .....	9
	Troubleshooting Guide.....	9
6	STANDARD PARTS LISTING	
	Standard Parts Listing Tables & Sectional Illustrations .....	10

## LIST OF ILLUSTRATIONS

Figure		<u>Page</u>
1	Valve Assembly .....	1
2	Adjustment .....	2
3	Bypass Installation .....	3
4	Exploded View - Typical 1/4" thru 1-1/2" Valve Assembly.....	5
5	Exploded View - Typical 2" Valve Assembly.....	7
6	Nameplate.....	8
7	Sectional View - 1/4" thru 2" Union End Valve Assembly.....	11

## LIST OF TABLES

Table		<u>Page</u>
1	Troubleshooting Guide.....	9
2	Standard Parts Listing for 1/4" through 2" 150# Union End Pressure Reducing Valve .....	10

## SECTION 1

### GENERAL INFORMATION

#### INTRODUCTION

The TRAC Style 'HG' pressure reducing valve is a spring loaded diaphragm operated device for regulating and reducing high pressure air or nitrogen to any desired operating pressure within its adjustable range.

#### PRINCIPLES OF OPERATION

Fluid enters the pressure reducing valve assembly (Figure 1) in the direction of the arrow cast in the body and passes downward through the seat to the outlet side of the valve. The outlet pressure is exerted on the underside of the diaphragm, indicated in the figure as the diaphragm chamber. The downstream pressure is obtained through an internal sensing line connected to outlet side port of the body. The spring is adjusted by turning the adjusting screw to balance the outlet pressure at any desired point within the range stamped on the nameplate. The pressure reducing valves will open or shut whenever this balance is changed due to any change in downstream pressure. The purpose of the O-ring on the valve stem is to form a piston seal to balance the pressure reducing valve. The seal ensures that variations in the inlet pressure will not change the downstream-regulated pressure.

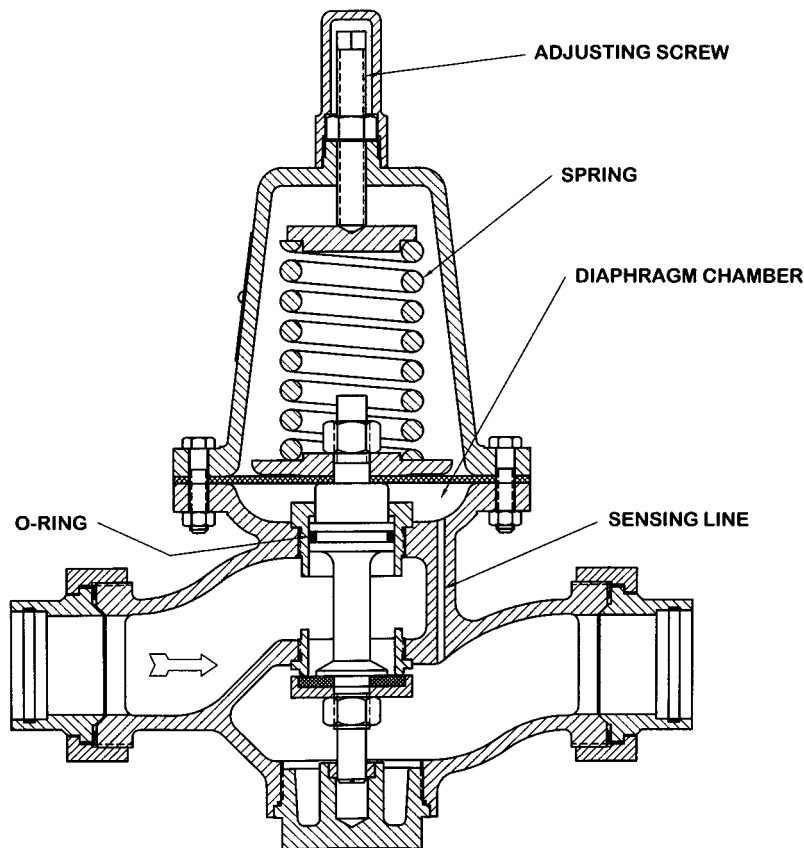

Figure 1 VALVE ASSEMBLY

## SECTION 2

### OPERATING INSTRUCTIONS

#### PRESSURE ADJUSTMENT

The valve can be set to control at any pressure within the limits of the pressure stamped on the nameplate. This type of valve is provided with spring adjustment. More or less tension of spring will cause the valve to control at a higher or lower pressure.

#### CHANGING PRESSURE SETTING

The valve can be set to control at any pressure within the limits of the pressure stamped on the nameplate. This type of valve is provided with spring adjustment. More or less tension of spring will cause the valve to control at a higher or lower pressure. See Figure 2 for pressure adjustment illustration.

To increase pressure, remove Cover (1), loosen Locknut (2) and turn Adjustment Spindle (17) clockwise.

To decrease pressure, remove Cover (1), loosen Locknut (2) and turn Adjustment Spindle (17) counter-clockwise.

After pressure setting adjustment has been made, always lock Adjustment Spindle (17) to prevent rotation with Locknut (2) and replace Cover (1).

#### IN SERVICE OPERATION

Once the valve has been set to design requirements, operation of the pressure reducing valves is automatic to control a preset downstream pressure. There is no in-service operator action required.

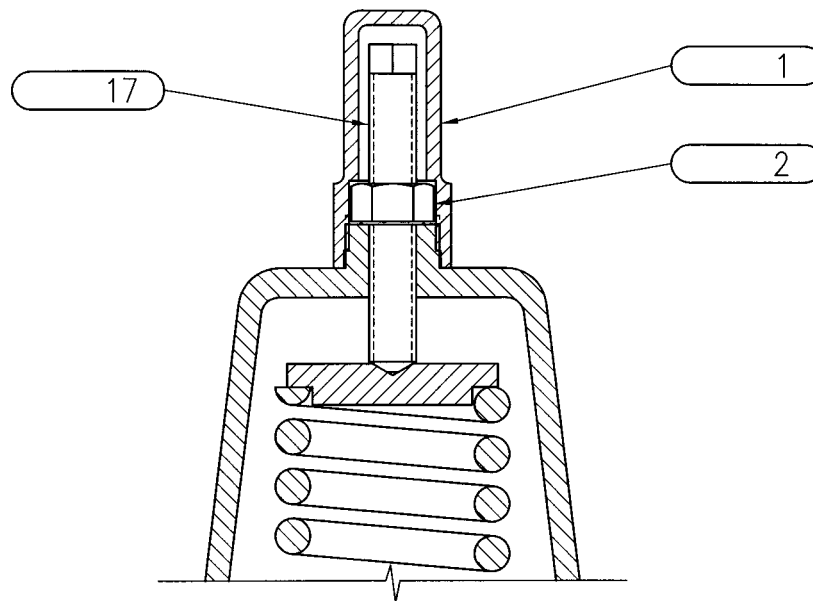

Figure 2 ADJUSTMENT

**SECTION 3**  
**INSTALLATION**

The pressure reducing valves must be clean and free from packing material and other foreign matter before installing into a clean pipeline. Connect the valve into the pipe line so that the flow is in the direction indicated by the arrow cast on the body. The valve will work equally well in any position, but it is preferable to install the valve with the adjusting spring vertically upward. This will minimize wear on all moving parts.

**BYPASS INSTALLATION**

Although not always required, it is a good engineering practice to install a hand operated bypass around any automatic control valve, thus, permitting uninterrupted service during necessary servicing of automatic devices. A typical installation diagram incorporating a bypass line is provided in Figure 3.

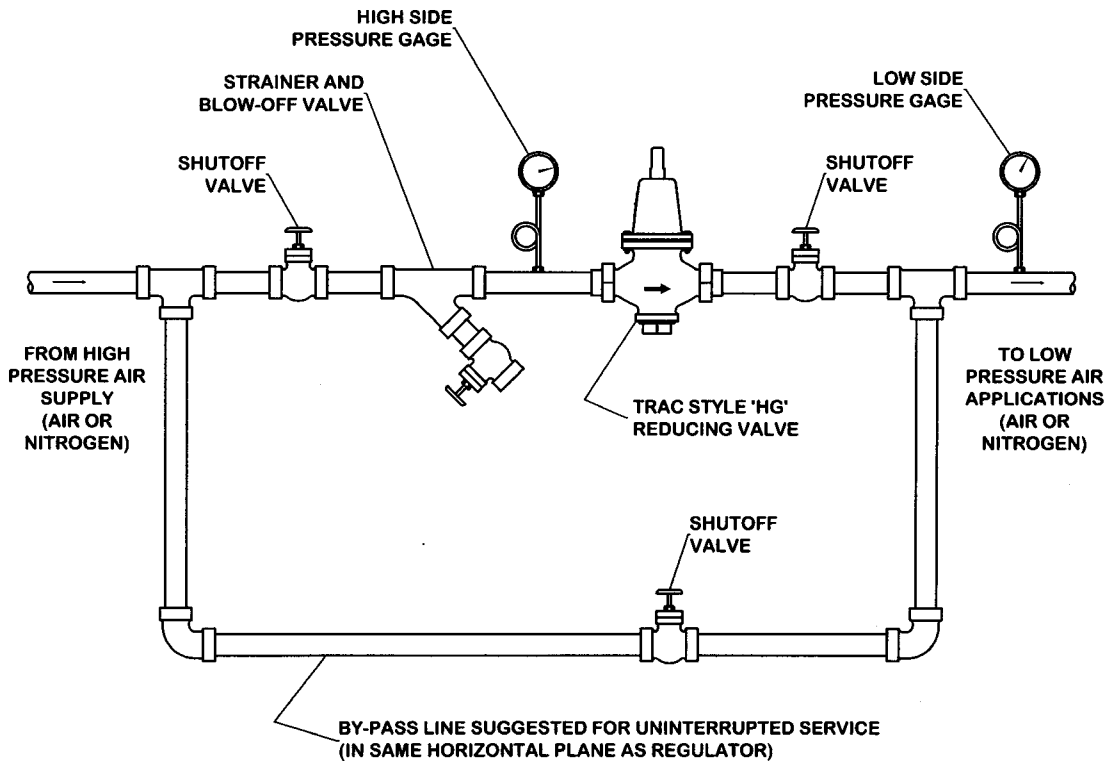

Figure 3 BYPASS INSTALLATION

**SECTION 4**  
**MAINTENANCE**  
**DISASSEMBLY**

**WARNING**

To prevent injury or death to personnel, ensure the air or nitrogen supply to the pressure reducing valve is depressurized and tagged OUT OF SERVICE.

- a. Shut off air or nitrogen supply to the pressure reducing valve, Tag air or nitrogen supply and pressure reducing valve OUT OF SERVICE according to ship's procedures.
- b. Loosen union nuts that connect valve body to piping to allow air or nitrogen to drain from body and piping, then remove valve from pipe line.

Disassemble the pressure reducing valve according to the following steps:  
(See Figure 4 for Illustration of Valve Assembly)

1. Ensure that procedures necessary to shut off the air or nitrogen supply to the pressure reducing valve have been completed and that all pressure has been relieved prior to disassembly or removal. Verify that the air or nitrogen supply and pressure reducing valve have been tagged OUT OF SERVICE according to ship's procedures.
2. Remove cover (1), loosen Locknut (2), and turn adjusting screw (17) counter-clockwise until all spring tension has been relieved.
3. Remove Nuts (25) and bolts (6). Lift off spring chamber (18).
4. Remove Spring Retainer (3) and Adjusting Spring (19 or other)(find no. varies by set pressure).
5. Apply wrench to flats at the top of the Stem (23), remove Stem Nut (21) and diaphragm plate (22).
6. Lift Diaphragm (7) and Diaphragm Disc (8)(for valve sizes 1/4" to 3/4" only) off of valve Stem (23).
7. Remove Bottom Plug Assembly (28, 29 and 20) and carefully slide valve Stem (23) out through the bottom of valve.
8. If necessary, the Liner (24) and Seat Ring (13) can be removed. Seat Ring tool (33) and Liner tool (32) are available, but not provided with valve. 1/4" to 3/4" valves use a 1" Hex deep socket for the Liner Tool.
9. Remove Seat Ring and Liner O-rings (26) and Stem O-ring (9).
10. To remove Disc (14) and Disc Holder (15) apply wrench to flats at the top of the Stem (23) and remove Disc Holder Nut (16).

SECTION 4  
MAINTENANCE  
DISASSEMBLY

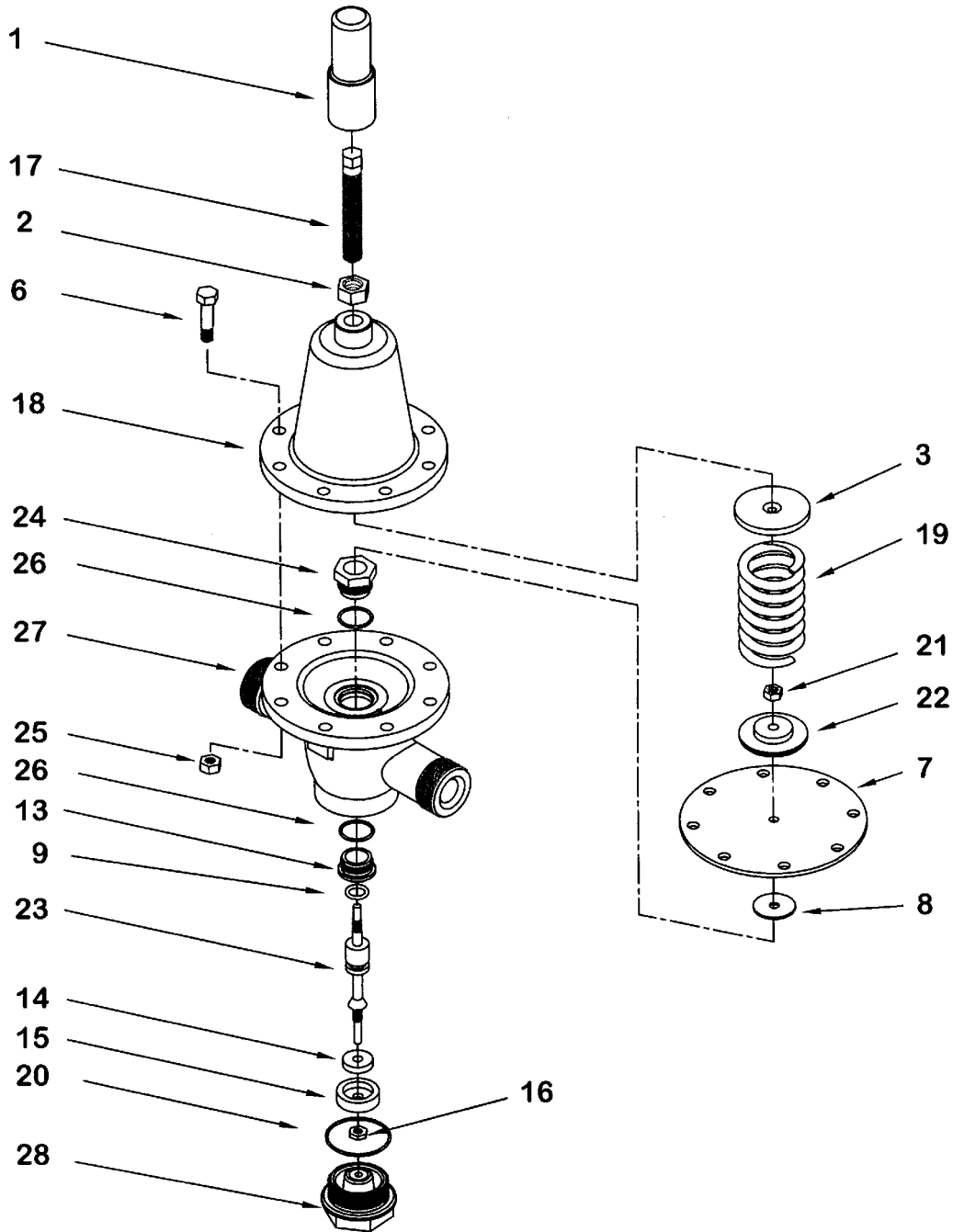

Figure 4 EXPLODED VIEW – TYPICAL 1/2" THROUGH 1-1/2" VALVE ASSEMBLY

**SECTION 4**  
**MAINTENANCE**  
**DISASSEMBLY**

**Disassembly of 2" Pressure Reducing Valve**

**WARNING**

To prevent injury or death to personnel,  
ensure the water supply to the pressure  
reducing valve is depressurized and tagged  
OUT OF SERVICE.

- a. Shut off water supply to the pressure reducing valve, Tag water supply and pressure reducing valve OUT OF SERVICE according to ship's procedures.
- b. Loosen union nuts that connect valve body to piping to allow water to drain from body and piping, then remove valve from pipe line.

Disassemble the pressure reducing valve according to the following steps:  
(See Figure 5 for exploded view Illustration of valve assembly)

1. Ensure that procedures necessary to shut off the water supply to the pressure reducing valve have been completed and that all pressure has been relieved prior to disassembly or removal. Verify that the water supply and pressure reducing valve have been tagged OUT OF SERVICE according to ship's procedures.
2. Remove cover (1), loosen Locknut (2), and turn adjusting screw (17) counter-clockwise until all spring tension has been relieved.
3. Remove Nuts (25) and bolts (6). Lift off spring chamber (18).
4. Remove Spring Retainer (3) and Adjusting Spring (19)(find number varies by set pressure- see individual drawing for specifics).
5. Apply wrench to flats at the top of the Stem (23), remove Stem Nut (21) and Diaphragm Plate (13).
6. Lift Diaphragm (16) and Diaphragm Disc (17) off of valve Stem (22).
7. Remove Bottom Flange Screws (30).
9. Remove Bottom Flange Assembly (28) and O-ring (20) and carefully slide valve Stem (23) out through the bottom of valve.
10. Remove the Liner (24) and Seat Ring (13). Seat Ring Tool (33) and Liner tool (32) are available, but not provided with valve.
11. Remove Seat Ring and Liner O-rings (26) and Stem O-ring (9).
12. To remove Disc (14) and Disc Holder (15) apply wrench to flats at the top of the Stem (23) and remove Disc Holder Nut (16).

SECTION 4  
MAINTENANCE  
DISASSEMBLY

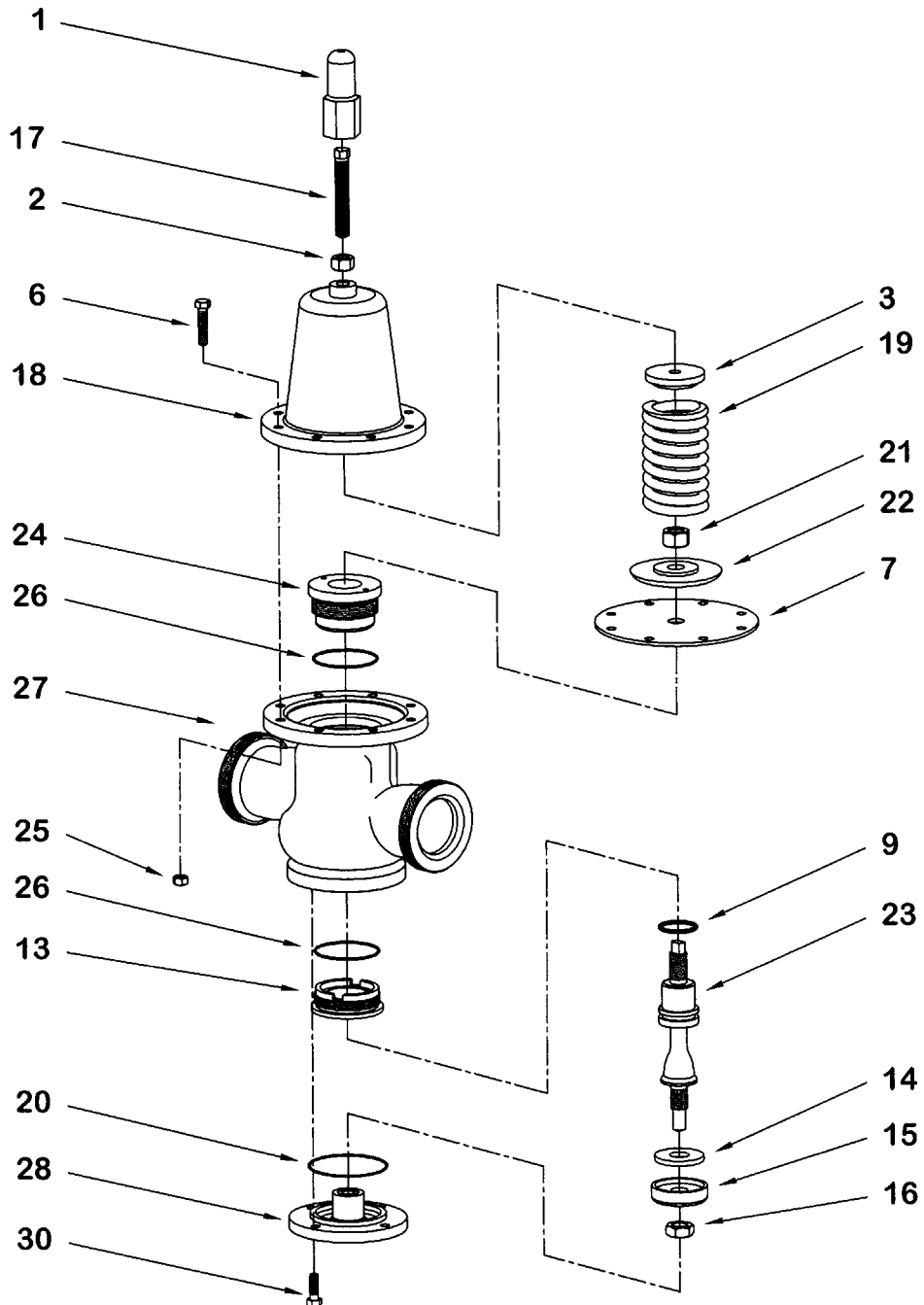

Figure 5 EXPLODED VIEW - TYPICAL 2" VALVE ASSEMBLY

## SECTION 4

### MAINTENANCE

#### INSPECTION AND REPLACEMENT OF PARTS

Check seat face of Seat Ring for smoothness. Check upper stem guide and O-ring seal surface of Liner. Check lower stem guide of Bottom Plug. Replace if scored or worn. Remove Liner and Seat Ring by unthreading from upper diaphragm area.

If the serviceability of any part is questionable, replace it. Replace all o-rings, seals, gaskets, and packing whenever valve is disassembled. Replace all discs and diaphragms that show signs of wear. If replacement parts are not available and the valve must be reassembled (due to emergency), used o-rings, seals, gaskets, and packing may be reused. If old parts are used the equipment should be closely monitored for leakage and proper operation.

#### REASSEMBLY

Reassemble in reverse order of disassembly procedure.

Restore air or nitrogen flow to the pressure reducing valve.

Adjust valve outlet pressure. Follow the instructions for Pressure Adjustment in Section 2.

Remove OUT OF SERVICE tags.

#### REFERENCE DATA

For specific information regarding a particular valve, consult the nameplate (Figure 5) affixed to the spring chamber of each production valve. For operating characteristics for a valve installed in a particular shipboard system consult the applicable certification data sheet or ship's drawing index.

MIL-SPEC. MIL-V-2961		
TYPE 1	CLASS 1	DESIGN A
NSN		
CID		
SERVICE		
INLET PSIG		
OUTLET PSIG		
RATED PSIG		
CAP.		SIZE
VALVE ID NO.		
SERIAL		STYLE
DATE MFG.		
TRAC Regulator Co., Inc.		
Mount Vernon New York USA		

Figure 6 NAMEPLATE

## SECTION 5

### TROUBLESHOOTING

This section provides information to aid qualified maintenance personnel in troubleshooting the pressure reducing valves. The most common malfunctions, their causes, and appropriate corrective actions are identified and listed in Table 1.

Preliminary troubleshooting consists of system checks and procedures to determine if all operating procedures have been performed correctly. Preliminary checks are performed to expedite the troubleshooting process and possibly eliminate the need for detailed troubleshooting which may involve the removal and disassembly of the valve from the system.

At the first sign of a malfunction, shut down the valve and its associated equipment. Check the procedure for startup and normal operation in section 2 to ensure that the procedures have been performed correctly.

The troubleshooting guide (Table 1) is used if the preliminary troubleshooting checks did not identify and correct the malfunctions. The procedures in the guide direct the user to the most probable cause of an observed malfunction. Recommended corrective action may be in the form of immediate action contained within the guide, or action requiring adjustment/ alignment or repair and overhaul.

Table 1 TROUBLESHOOTING GUIDE

Malfunction	Probable Cause	Corrective Action
Valve Will Not Open	Valve Installation	Valve was installed backwards, verify that the arrow cast on the valve body points in the desired direction of flow
Valve Will Not Control Pressure	Sensing Line in Valve Body Blocked	If this hole becomes plugged it will keep the valve in whatever position it is in. To check it, disassemble and push the appropriate sized drill into the hole. For valve sizes 1/4" through 2" use a 1/8" drill.
	Upper and Lower Guide Surfaces Damaged or Dirty	Disassemble, Clean and Replace Scored or Worn Parts: Stem, Liner, and/or Bottom Plug
Valve Will Not Shut (Inlet and Outlet Pressure are the Same Regardless of Demand Downstream)	Leak in Diaphragm	Disassemble; Replace Diaphragm
Valve Will Not Shut (Outlet Pressure Continues to Rise Above Lockup Pressure When There is No Demand Downstream)	Stem O-Ring is Damaged	Disassemble, Clean and Replace Scored or Worn Parts: Stem, Liner, and/or Stem O-Ring
	Damaged Disc or Seating Surface	Disassemble, Clean and Replace Scored or Worn Parts: Seat Ring, and/or Disc
	Seat and/or Liner O-Ring is Damaged	Disassemble, Clean and Replace Scored or Worn Parts: Seat and/or Liner O-Ring

**SECTION 6**

**STANDARD PARTS LISTING**

NOTE: This table and associated illustration are provided to list standard parts for valves normally supplied for shipboard air or nitrogen service. For application specific information consult the applicable certification data sheet for operating characteristics, Trac valve identification number, drawing number and revision, and departures from the manufacturer's drawings. When possible, consult the applicable drawing revision for parts and materials listing specific to that equipment. See Figure 7 for Illustration of Valve Assembly.

Table 2 1/4"–2" 150# UNION END

FIND NO.	1/4"	3/8"	1/2"	3/4"	1"	1-1/4"	1-1/2"	2"
1	919-02							
2	164-28							
3	921-01				736-03			
4	174-00							
5	464-01							
6	144-44				144-38			
7	923-01				733-02		733-03	
8	970-00				NOT APPLICABLE			
9	432-02				429-02		750-01	428-02
10	1104-00	1066-00	192-00	193-00	194-00	195-00	196-00	197-00
11	928-00	1150-00	180-00	181-00	182-00	183-00	184-00	185-00
12	1105-00	1067-00	186-00	187-00	188-00	189-00	190-00	191-00
13	930-02				730-04		906-04	768-04
14	931-01				729-01		910-01	769-01
15	932-00				728-00		909-00	770-00
16	164-33				164-21		164-18	
17	737-02							
18	934-00				961-00			
19	1215-00				724-00			
20	942-00				845-00		652-00	718-00
21	164-34				164-22		164-20	
22	936-01				734-01		763-03	
23	937-00				727-00		907-00	762-00
24	925-00				731-00		908-00	765-00
25	164-19							
26	938-00				740-00		746-00	757-00
27	1098-00	1080-00	947-00	957-00	722-00	886-00	916-00	879-00
28	60144-00				60080-00		60137-00	60088-00
29	NOT APPLICABLE							144-40
30	1149-00	1351-00	263-00	264-00	265-00	266-00	267-00	268-00
31	1578-00	938-02	269-01	270-01	271-02	272-03	273-02	274-02
32	1230-00				60398-00		60399-00	60400-00
33	NOT APPLICABLE				60391-00		60392-00	60393-00

DISTANCE TO DISSEMBLE

D

$$C \pm \frac{5}{16}$$

E

$$B \pm \frac{3}{16}$$

DISTANCE TO DISSEMBLE

$$A \pm \frac{1}{8}$$

ADJUSTING SPRING CHART (PC. NO. 19)									
VALVE SIZE	ADJUSTABLE RANGE (PSIG)								
	5 - 30	5 - 60	5 - 150	25 - 60	50 - 100	50 - 125	50 - 150	75 - 150	100 - 200
1/4" - 3/4"		1215-00	1588-00						
1" - 2"	724-00			1581-00		1583-00			1350-00

VALVE DIMENSIONS						
VALVE SIZE	'E' DIM.	'D' DIM.	'C' DIM.	'B' DIM.	'A' DIM. 150-400#	'A' DIM. 600#
1/4"	8-3/4	12	9-1/4	2-5/16	8-13/16	8-15/16
3/8"	8-3/4	12	9-1/4	2-5/16	9	
1/2"	8-3/4	12	9-1/4	2-5/16	9-3/16	9-13/32
3/4"	8-3/4	12	9-1/4	2-5/16	9-5/8	9-3/4
1"	8-3/4	12	11-5/8	3-1/8	9-7/8	10
1-1/4"	9	12-1/2	11-5/8	3-1/8	10-7/8	10-29/32
1-1/2"	9-1/2	13	11-1/2	3-1/4	11-15/16	12-3/32
2"	11	13	12	3-1/2	13-13/16	13-11/32

TORQUE REQUIREMENTS FOR STYLE 'H' VALVES															
NOTE: UNLESS A TORQUE IS SPECIFIED IN THE TABLE, TORQUE TOLERANCE IS +/- 10% FOR ALL VALUES															
PIECE TO PIECE	DESCRIPTION	1/4"+3/8"		1/2"		3/4"		1"		1-1/4"		1-1/2"		2"	
		in/lb	ft/lb	in/lb	ft/lb	in/lb	ft/lb	in/lb	ft/lb	in/lb	ft/lb	in/lb	ft/lb	in/lb	ft/lb
13 TO 27	SEAT TO BODY	50	4.2	50	4.2	50	4.2	200	16.7	200	16.7	200	16.7	150	12.5
24 TO 27	LINER TO BODY	50	4.2	50	4.2	50	4.2	200	16.7	200	16.7	200	16.7	150	12.5
16 TO 23	DISC NUT TO STEM	8	---	8	---	8	---	50	4.2	50	4.2	100	8.5	120	10
21 TO 23	DIAPHRAGM NUT TO STEM	50	4.2	50	4.2	50	4.2	150	12.5	150	12.5	150	12.5	150	12.5
28 TO 27	BOTTOM PLUG TO BODY	350	29.2	350	29.2	350	29.2	450	37.5	450	37.5	520	43.4	150	12.5
30 TO 27	BOTTOM FLANGE BOLTS TO BODY	---	---	---	---	---	---	---	---	---	---	---	---	150	12.5
6 TO 25	SPRING CHAMBER NUTS BOLTS	50	4.2	50	4.2	50	4.2	150	12.5	150	12.5	150	12.5	150	12.5

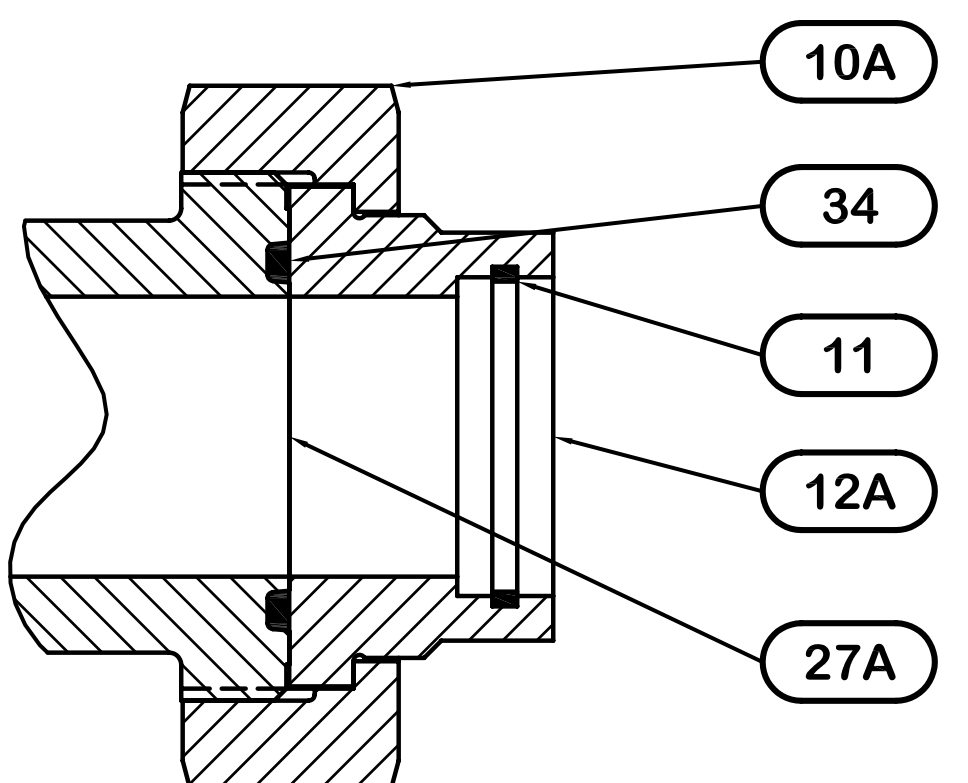

LIST OF MATERIAL						
PC. NO.	DESCRIPTION	QTY.	MATERIAL	MATERIAL SPEC.	PART NO.	REMARKS
1	COVER	1	CST. BRONZE	ASTM-B61		
2	LOCK NUT	1	COR.RES.ST.	QQ-S-763		
3	SPRING RETAINER	1	COR.RES.ST.	QQ-S-763		CLASS 303 - COLD - COND.A
4	DRIVE SCREW	2	COR.RES.ST.	QQ-S-763		
5	NAME PLATE	1	COR.RES.ST.	QQ-S-763		
6	BOLT	8	COR.RES.ST.	ASTM-F-593		MATERIAL GROUP I, COND.CW
7	DIAPHRAGM	1	BUNA-N	COMMERICAL		
8	DIAPHRAGM DISC - LOWER	1	MONEL	QQ-N-281		1/4"-3/4" VALVES ONLY
9	O-RING - STEM	1	BUNA-N	MIL-P-25732		
10	UNION NUT	2	CST. BRONZE	MIL-F-1183		
10A	UNION NUT	2	CST. BRONZE	QQ-C-390		810-1385946 (600# ONLY)
11	BRAZING RING	2	SIL.BRAZ.ALY.	MIL-F-1183		
12	UNION TAILPIECE	2	CST. BRONZE	MIL-F-1183		
12A	UNION TAIL PIECE	2	CST. BRONZE	QQ-C-390		810-1385946 (600# ONLY)
13	SEAT RING	1	CST. MONEL	ASTM-A-494		COMP.M25-S
14	DISC	1	BUNA-N	MIL-P-25732		
15	DISC HOLDER	1	CST. MONEL	ASTM-A-494		COMP.M35-2 OR M30C
16	NUT - DISC HOLDER	1	MONEL	QQ-N-281		
17	ADJUSTMENT SPINDLE	1	COR.RES.ST.	QQ-S-763		CLASS 303 - COLD - COND.A
18	SPRING CHAMBER	1	CST. BRONZE	ASTM-B61		
19	SPRING - ADJUSTING	1	COR.RES.ST.	ASTM-A-313		(SEE SPRING TABLE)
20	O-RING - BOTTOM PLUG	1	BUNA-N	MIL-P-25732		
21	NUT - STEM	1	COR.RES.ST.	QQ-S-763		
22	DIAPHRAGM PLATE	1	COR.RES.ST.	QQ-S-763		CLASS 303 - COLD - COND.A
23	VALVE STEM	1	CST. MONEL	ASTM-A-494		COMP. M35-2 OR M30C
24	LINER	1	CST. MONEL	ASTM-A-494		COMP. M25-S
25	NUT	8	COR.RES.ST.	ASTM-F-594		MATERIAL GROUP I, COND. CW
26	O-RING SEAT & LINER	2	BUNA-N	MIL-P-25732		
27	BODY	1	CST. BRONZE	ASTM-B61		
27A	BODY	1	CST. BRONZE	ASTM-B61		810-1385946 (600# ONLY)
28	BOTTOM PLUG ASSY.	1	CST. BRONZE	ASTM-B61		HAS S-MONEL INSERT
29	BOLT	4	COR.RES.ST.	ASTM-F-593		MATERIAL GROUP I, COND.CW (2" VALVE ONLY)
30	RETAINING RING	2	CST. BRONZE	ASTM-B61		
31	O-RING UNION END	2	VITON	MIL-R-83248		
32	TOOL - LINER	1	STEEL	COMMERICAL		NOT SUPPLIED WITH VALVES
33	TOOL - SEAT	1	STEEL	COMMERICAL		NOT SUPPLIED WITH VALVES
34	O-RING UNION END	2	BUNA-N	MIL-P-25732		(600# ONLY)

TOLERANCES UNLESS OTHERWISE SPECIFIED: SURFACE FINISH: 125RHR FRACTION: +/- 1/64 DECIMAL: +/- .005 ANGLE: +/- 1/2"	TRAC REGULATOR CO., INC. MOUNT VERNON, NEW YORK 10550		
	1/4" - 2" TRAC STYLE 'HG' GAS PRESSURE REDUCING VALVE PER MIL-V-2961D TYPE I CLASS 1 BODY A SERIES 400# THRU 600# UNION END		
DATE: 12/1/05 DRAWN BY: L.B. APPROVED:	SIZE: D 55378	FSCM NO.: DRAWING NO.: FIGURE 7	REV.: SCALE: NTS WT. ACT.: SHEET 1 OF 1

